

Installation Instructions

Fallnet® SR Rail

When used in conjunction with a superimposed load from a suitable bulk material (e.g. ZinCo System Substrates, Zincolit® or gravel 16/32 mm), the Fallnet® SR Rail stands as a fixing device, in accordance with DIN EN 795:2012 Types D and E, to form a safety device on flat roofs with up to 5° of inclination.

A fixing point (the so-called runner) may only be used by one person (up to 100 kg) at a time and this person should be wearing personal protective equipment (PPE, e.g. ZinCo PPE-Set) in accordance with DIN EN 363. The safety harness, in accordance with DIN EN 361, can only be used in conjunction with tested and approved components.

Important note:

We would like to state explicitly that, regardless of product liability, ZinCo shall only assume liability for the consultancy process where installation has been carried out in line with ZinCo site planning. Installation without planning carried out by ZinCo is at your own risk. Regardless of this, the Installation Instructions and Instruction for Use must be observed. We recommend having Fallnet® SR Rail planned or checked by ZinCo Technical Department before starting installation.

1. Prior to installation

1.1 Check of the scope of delivery and condition of system components

The delivery of an object-specific Fallnet® SR Rail safety device comprises:

A. Fallnet® SR Rail components, like e.g.

Pre-assembled grid units each of them consisting of 12 individual grids to complete the grid units AE (rail start or rail end) and grid units M (rail centre);



Rail support consisting of a base plate with locking tabs and a stainless steel support with a square-head bolt;

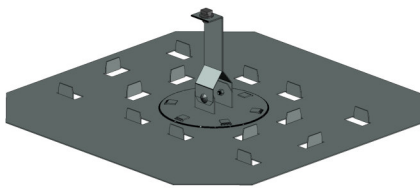

Rails made of a high quality aluminium alloy in standard lengths of 2.0 m, 3.0 m and 6.0 m, butt joint connectors, end pieces, runners, etc.



The required quantities and characteristics of the components can be found in the delivery note.

B. Documents included with each order:

Installation Instructions, User Instructions and Control Card. The installation plan (if planned by the ZinCo GmbH) is provided separately to the person stating the order and is to be handed to the client.

Please note:

Incomplete, incorrect or defective deliveries are to be objected immediately.

1.2 Check of the initial situation

Before starting installation, check whether the roof construction is suitable for the loads to be applied, make sure that the maximum possible roof pitch (5°) is not exceeded, check whether the waterproofing, root protection, etc. have been applied professionally. If there are any doubts, these must be clarified and if necessary eliminated before installation.

1.3 Admissible types of installation

The following types of installation are admissible for Fallnet® SR Rail:

A. With multi-layer build-ups:

Fallnet® SR Rail is applied above the drainage layer directly over the corresponding filter sheet.

B. With mono-layer build-ups:

Fallnet® SR Rail is applied directly over the protection layer (> 300 g/m²).

1.4 Assembly of the grid elements

The sets of grid elements consist of the following components:

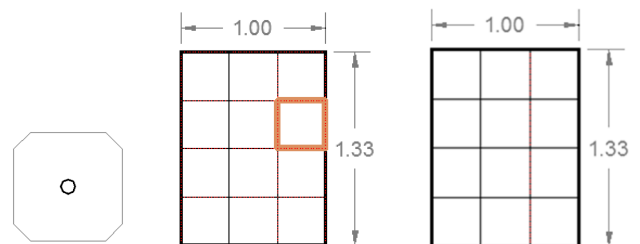

Base plate with rail support

Pre-assembled set of grid elements with colour coding

Pre-assembled set of grid elements without coding

To achieve the frictional connection between rail supports and grid units, the first grid element unit is moved over the rail support with its colour coding and pressed by foot to snap. Install all grid units in such a way that the rail support is located centrally in the grid unit (one more in the centre resp. two more at the beginning and the end of the rail). All grid elements of a grid unit must be plugged together at the connection points and thus form a tension distributing disc.

Installation Instructions

Fallnet® SR Rail

A **Grid Unit M** consists of one rail support with a square-head bolt and **two** pre-assembled grid units:

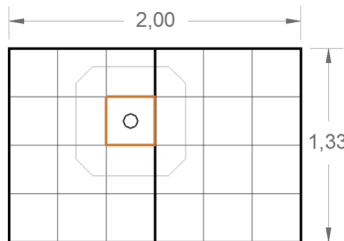

Grid Unit M
(Grid unit for the centre of the rail)

A **Grid Unit AE** consists of one rail support with a square-head bolt and **three** pre-assembled grid units one of which needs to be divided:

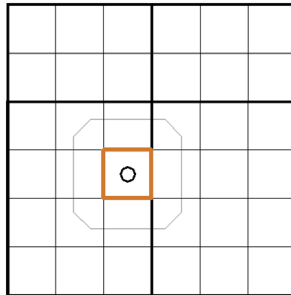

Grid Unit AE
(Grid unit for the beginning and the end of the rail)

→ **Important:**

Check the connecting points between the interconnected grid units, replace damaged grid elements if necessary.

2. Installation instructions

2.1 Measuring the grid units

The course of the rail is measured and the grid units AE and M are positioned according to the dimensioned site planning. The distance between the rail supports within the course of the rail may not exceed 4.50 m. The entire surface of the grid units must be placed on the permanently even base described under 1.3.

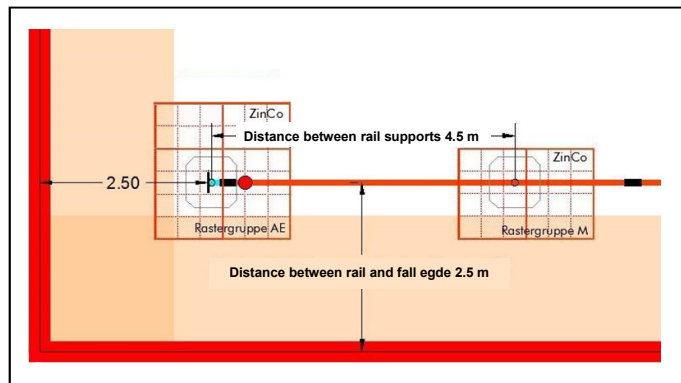

Extract from a site planning

2.2 Assembly of the rail

Required tools:

- wrench/ratchet 17.0
- allen or allen key size 6.0
- torque wrench
- optionally ZinCo Drilling Set to manufacture rail pieces of special lengths on-site

Depending on the site planning a rail can consist of the following:

- rail 6 m
- joint connector
- 3-way-switch
- rail 3 m
- end piece
- runner
- rail 2 m
- 90°-corner piece
- rail special length

- Every rail support is equipped with a square-head bolt. Using this square-head bolt the rail is threaded with the T-slot and thus connected to the already positioned grid unit.

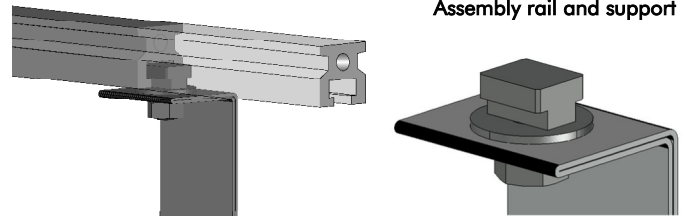

Assembly rail and support

- The rail track is extended by attaching further pieces of rail by means of butt joint connectors. The self-locking nuts are to be tightened manually (max. 20 Nm). A maximum gap of 5 mm between the rail pieces is to be observed.

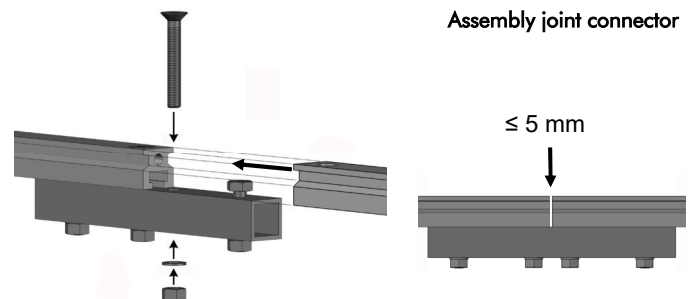

Assembly joint connector

- Before completing the rail track, insert the mobile attachment point (runner) onto the rail.
- Any required fitting pieces can be manufactured directly at the construction site using the ZinCo Drilling Set (see separate instructions).
- Depending on the site planning, a closed loop-shaped system or a termination with ending pieces is possible.
- Finishing with rail end pieces: Screw end pieces onto the ends of the rail using butt joint connectors. The end pieces are threaded over the rail support of the grid unit AE and fastened between the first or last butt joint connector and the stop screw of the end piece (available room approx. 120 mm). A longer rail overhang is not permitted!

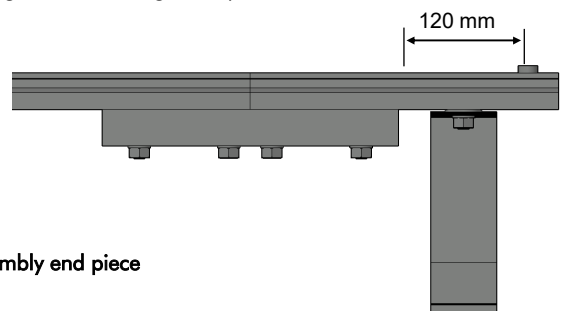

Assembly end piece

- Check if the positioning of the rail course and the rail supports with the grid units complies with the site planning and, correct them if necessary.
- Finally, check all screw connections and tighten them.



Installation Instructions

Fallnet® SR Rail

Important:

In general, the material temperature during installation should not be **below +5 °C**.

Applying the graphite or copper paste which is included in the delivery will prevent the stainless steel screws from seizing.

Possibilities of adaptation to rising components etc.:

- The grid units can be turned without a change of the position of the rail support
- The grid units can be moved including the rail support (be aware of the maximum axis dimension of 4.5 m)
- Small obstacles, like e.g. roof outlets or aeration shafts can be enclosed by repositioning single grid elements (0.33 m x 0.33 m). However, the rail support is not to be situated within the outermost row of grid elements.

2.3 Application of the required load

Prior to the application of the required load the on-site situation needs to be documented and photographed if necessary.

Documentation - Corresponding templates can be found under:
http://www.zinco.de/sites/default/files/products/data_sheets/2017-04/ZinCo_Montagedok.%2BKontrollk._Fallnet_SR-Rail.pdf

The grid elements of Fallnet® SR Rail need to be filled and covered entirely and uniformly with suitable bulk material. This can be done using ZinCo System Substrates, Zincolit®, 16/32 mm gravel or a similar bulk material.

Required load for Fallnet® SR Rail:

min. **110 kg/m²** (roof inclination 0° to 2°)
min. **130 kg/m²** (roof inclination > 2° to 5°)

The values apply for the dry state of the bulk material. The layer thickness of the bulk material used depends on its bulk density (dry). For reasons of UV protection, a gravel cover must reach at least 50 mm above the upper edge of the plastic grid.

Important: Direct contact between the load (bulk material) and the grid elements is required at all times.

3 Completion

Make sure that all work is done professionally according to the site planning and the Installation Instructions. Check the identification label at the point of entry, it must be permanently well recognizable. Only rail systems marked with a label may be used.

3.1 Installation documentation

The installation documentation allows for providing evidence of a professional installation to the client. Furthermore it is an indispensable base for future inspections of the Fallnet® SR Rail fixing devices.

A template for the installation documentation is available as a PDF file from the manufacturer. Document copies must be handed over to the client after installation and must be kept on the object for future inspections of the Fallnet® SR Rail.

Required information:

- address of property
- installation company
- technician in charge of installation
- Fallnet® SR Rail serial number (see runner or label)
- details of superimposed load (type of bulk material, weight, include delivery note if relevant)
- site planning (please include serial number(s) here too)

The site planning should be affixed to the building where it is clearly visible, e.g. at the roof access point.

Statement issued by the technician in charge of installation (signature):

- the Fallnet® SR Rail Installation Instructions were adhered to
- installation was carried out as planned
- the minimum load requirements have been adhered to
- photo documentation, in particular of details that are no longer visible after installation.

3.2 Handing over the Fallnet® SR Rail documentation to the client/owner

The delivery scope includes the following documents, which the installer must hand to the client:

- Installation Instructions and User Instructions
- Installation documentation
- Control card, Fallnet® SR Rail must be maintained and inspected regularly. Please enter serial numbers (see runner or label)
- Site planning

3.3 Queries

Should you have any queries, or be unsure about the correct use/installation of the product or require further detailed information for your own specific building project, please contact ZinCo GmbH, Hotline phone +49 7022 6003-0.

User Instructions

Fallnet® SR Rail

Your roof protects your building, the contents and any valuables in it. In order to have the benefit of a fully-functioning roof over a long period of time, your roof must be installed professionally and must be inspected at regular intervals during its lifetime and, where necessary, repair work carried out. Therefore, it is important to ensure that any works on the roof are carried out safely. The client (and later on possibly other) owner also have a duty here and are responsible for adherence to any regulations pertaining to occupational safety on a roof.

Used in combination with a load of suitable material (e.g. Green Roof substrates, Zincolit® or gravel), Fallnet® SR Rail provides a fixing device in accordance with DIN EN 795:2012 Type E and D for fall protection on flat roofs.

1. Fallnet® SR Rail - System components:

a. Grid elements

Discs formed of interconnected grid elements made of RC polyethylene, single size each about 0.33 x 0.33 m, height about 30 mm, which can absorb and derive load in the event of a fall. The grid units at the start and end supports consist of 36 individual grid elements each (surface area approx. 4.0 m² each) and the grid units under the central supports each consist of 24 individual grid elements (area approx. 2.7 m² each). The plastic grid elements are no longer visible after installation. A load of at least 110 kg/m² or 130 kg/m² applied at > 2° roof pitch, is to be superimposed e.g. in the form of ZinCo System Substrate, gravel 16/32 mm or equivalent.

b. Rail support

A rail support is placed in the centre of each of these load-bearing discs. Its approximately 0.75 x 0.75 mm aluminium base plate lies under the grid elements and its 225 mm high stainless steel support reaches up through the grids. The distance between the rail supports may not exceed 4.50 m.

c. Rail with runner, further accessory

The supports are connected by an anchorage rail made of high quality aluminium. A mobile attachment point runs along the rail on its four stainless steel rollers (therefore also called "runner"). The carabiner hook of the personal protective equipment can only be attached to the eyelet of this runner. In order to prevent the runner from slipping off the rail at its ends, end pieces with "stoppers" must be mounted there. The single pieces of the rail, which have a length of up to 6 m, are held together by special butt joint connectors. Gaps between two pieces shall not exceed 5 mm.

d. Documents

The delivery scope includes the following documents, which the installer must hand to the client:

- Installation Instructions
- User Instructions
- Control Card. Please record the serial number of the Fallnet® SR Rail in the chart. This number can be found on the identification label attached to the product. Fallnet® SR Rail must be inspected regularly.

Furthermore the following documents need to be handed over:

- installation documentation
- eventually separate site planning (if planning was done by ZinCo).

2. Scope and requirements for use

Fallnet® SR Rail must only be used for the intended purpose as a fixing device for personal protection equipment. Fallnet® SR Rail must not be used for lifting weights or for attaching objects. Any modification or addition to any of the system components requires the prior written permission of the manufacturer.

Please note also:

- Fallnet® SR Rail may only be used by max. 1 person (max. 100 kg, including equipment) in conjunction with personal protective equipment (PPE, such as the ZinCo PPE-Set) acc. to DIN EN 363. The harness according to DIN EN 361 may only be used with tested and approved components.
- Additional persons (max. 100 kg, including equipment) can use the rail system with an additional attachment point (runner), if it is ensured that there is at least one free field between two rail supports.
- The use of Fallnet® SR Rail is permitted up to a maximum roof inclination of 5° in the direction of the edge which is to be secured.
- Fallnet® SR Rail should only be installed on suitable subsurfaces e.g. either on the filter sheet (multi-layer build-up) or on a protective mat (mono-layer build-up), see Installation Instructions.

Important: Direct contact between the load (bulk material) and the grid elements is required at all times.

If the site planning is done by ZinCo GmbH, Fallnet® SR Rail is always applied as a fall arrest system. This means that it is planned with a uniform rope length, which is dimensioned so that the roof edge can be reached, but one can not fall at all. The planning can be done in such a way that the rail runs partly through the area at risk of falling (≤ 2 m to the fall edge), provided that the entry point is located outside the danger zone.

Nevertheless, misuse - in particular an incorrectly set rope length - can never be completely ruled out. Fallnet® SR Rail has therefore proven in extensive tests that it can also reliably absorb a fall.

Precondition for this is that the minimum fall distance to the ground (fall height) must be such as to prevent a person hitting the ground in the case of a fall event and to allow the person to swing freely.

The required minimum fall distance to the ground (potential impact area) is resulting from the following parameters:

- the part of the connecting device being pulled over the fall edge (= maximum rope length to the fall edge minus the shortest rope length, rectangular to the fall edge),
- height the person attached,
- stretch of rope and safety harness
- rupture distance of the fall absorber
- displacement and deformation of fixing device (max. 1.0 m) and
- 1.0 m safety value.



User Instructions

Fallnet® SR Rail

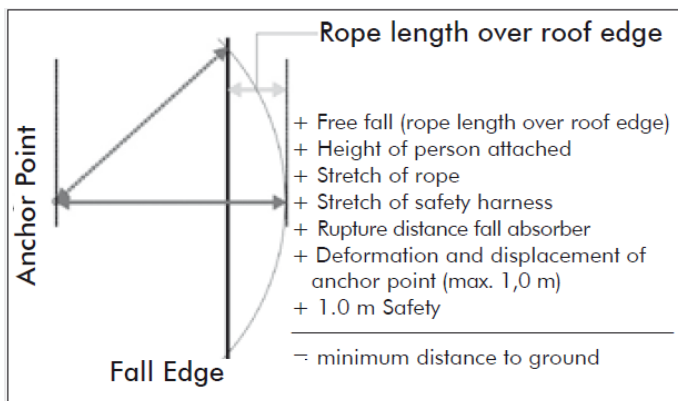

- In the case of a fall event, the person may swing to and fro. It is important to ensure that there are no building elements in the way (e.g. balcony, awning etc.) and that impact is prevented.

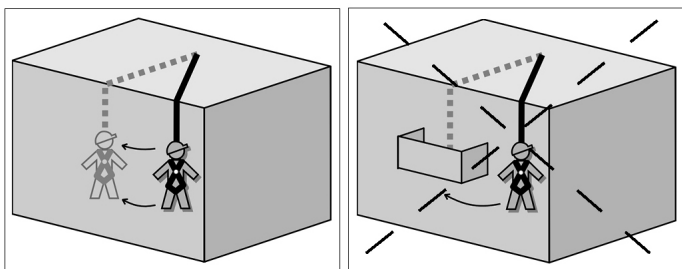

It is important that Fallnet® SR Rail is only used in conjunction with a suitable "personal protective equipment against falling", which of course must be set correctly. This "PPE" according to DIN EN 363 (not included in the Fallnet® SR Rail fall protection device) must contain the following components:

- safety harness in compliance with DIN EN 361
- fall absorber in compliance with DIN EN 355 or safety appliance for use at height in compliance with DIN EN 360 (arresting forces ≤ 6.0 kN each)
- connecting device (rope) according to DIN EN 354
- connecting elements (carabiner) in compliance with DIN EN 362

Please ensure that the individual system components are compatible and suitable for use on the horizontal and for a fall event over a roof edge. Potential danger resulting from a combination of the components used (in particular fall absorber, DIN EN 355 or safety appliance for use at height, DIN EN 360) should be eliminated. Therefore, prior to using personal protective equipment for fall arrest we recommend that you seek the advice of the manufacturer of the PPE. Please observe the manufacturer's User Instructions.

The following hazards may impact the proper functioning of the equipment: e.g. putting stress on the connection devices due to sharp edges, cuts, abrasion, slack rope, chemical, electric or climatic impact, extreme temperatures, swinging movement in the event of a fall. The connection devices, therefore, should always be inspected prior to use and if necessary, an edge protector must be provided.

Fallnet® SR Rail requires no special cleaning procedures; if necessary, dirt can be removed with a damp cloth.

The fixing device may be used in frosty conditions provided the device was installed in frost-free conditions.

3. Requirements for the use and for the user of Fallnet® SR Rail

The fall protection system Fallnet® SR Rail must only be used by persons who have been instructed in the safe use of the equipment, who have the necessary knowledge and who, in terms of their health, are capable of using the equipment (e.g. no impairment due to medication, alcohol abuse, coronary or circulatory problems etc.).

The user is to be instructed such that s/he will carry out the following visual and manual inspections of the fixing device prior to each use:

- manual tensile loading and visual inspection of the visible stainless steel components, the support and the anchor eye
- visual inspection of the load height

Indications that the good working condition of the fixing point is restricted could be:

- any rail components are deformed, weakened, soiled or are not in their original condition,
- the mobile attachment point (runner) does not sit firmly on the rail or even can be removed from it during manual testing
- there is an uneven level of superimposed material, e.g. as a result of drifting
- the grid elements are visible.

If there are concerns about the safe condition or the proper functioning of the fall protection device, the builder/the owner must be notified. It must not be used until the doubts are clarified.

The use of the fall protection device must be in accordance with the utilization plan. If no utilization plan is available, the rope length of the PPE should always be adjusted in a way that a possible fall is ruled out or a possible swinging fall does not result in an impact.

Prior to use, an emergency plan must be available in which all possible occupational emergency situations are addressed.

At the request of the client/owner, an inspection of the proper functioning of the entire safety equipment is to be carried out:

1. **at least once a year**
2. **if required**, e.g. if there is doubt about the proper functioning of the equipment (see "Indications of restricted functioning")
3. **after 10 years a complete inspection** to be carried out by the manufacturer

The equipment must only be inspected by persons qualified to do so and details of all inspections must be recorded in the inspection chart. The relevant check list is available in PDF from the manufacturer.

User Instructions

Fallnet® SR Rail

Attention:

After a fall event the fall protection system Fallnet® SR Rail must be **removed from service immediately**. It can only be released for use again after testing and repair by a knowledgeable person.

The product Fallnet® SR Rail must only be used for the purpose and application as described. The manufacturer accepts liability for the product within the framework of applicable statutory requirements.

The manufacturer accepts no liability for any other deviating use of the product. Furthermore, the manufacturer accepts no liability where the Installation Instructions and the User Instructions have been insufficiently adhered to. We wish to state explicitly that, regardless of product liability, ZinCo shall only assume liability for the consultancy process where installation has been carried out in line with ZinCo site planning. Installation without site planning carried out by ZinCo is at your own risk.

Where the fixing device Fallnet® SR Rail is sold in another country, the technician/user must receive a copy of the Installation/User Instructions and the Control Card in the language of that country.

4. Label

Every runner is equipped with an identification label. The label contains the following information:

Manufacturer: ZinCo GmbH **Type:** Fallnet® SR Rail

Standard: Fall Protection System **Year of manufacture:**

acc. to DIN EN 795:2012, Date of manufacture (year)

Type D+E

Serial-No.: **max. 1 person:** max. number of users



The notified body nominated for certification



Note that the Instruction Manual is to be observed



Fall protection equipment only to be used with a fall absorber

5. Details of manufacturer and testing institute

Manufacturer:

ZinCo GmbH
Lise-Meitner-Straße 2
72622 Nürtingen, Germany
Phone +49 (0) 7022 9060-770
E-Mail: info@zinco-greenroof.com
www.zinco-greenroof.com

Testing institute:

DEKRA EXAM GmbH
Dinnendahlstraße 9
44809 Bochum, Germany

Main steps of the installation of Fallnet® SR Rail

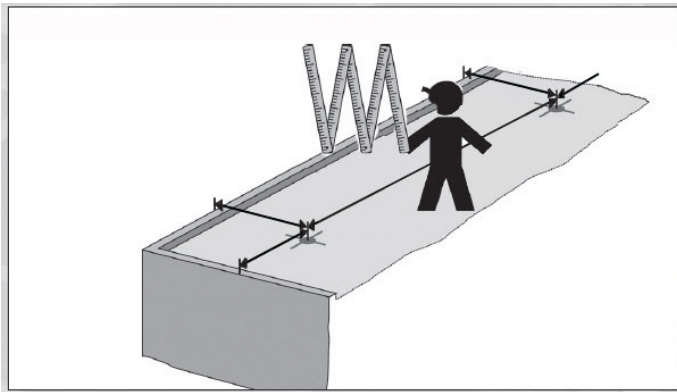

1. Measuring the position of the single rail supports according to the site planning.

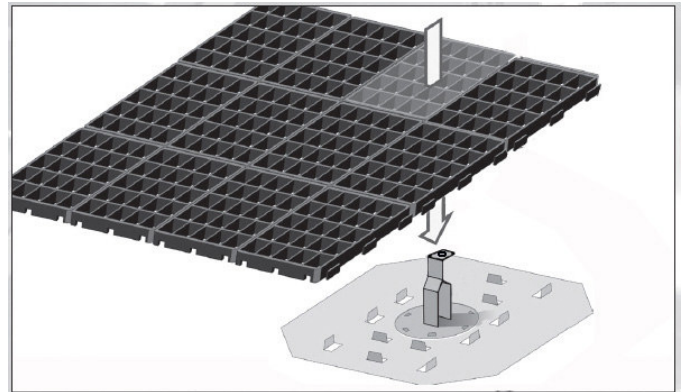

2. Placing the colour-marked grid element over the rail support and pressing it down.

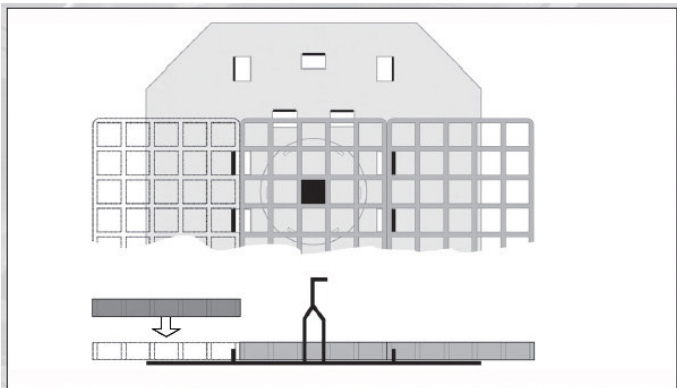

3. The grid must fully cover the base plate and the vertical locking tabs must engage the adjacent elements.

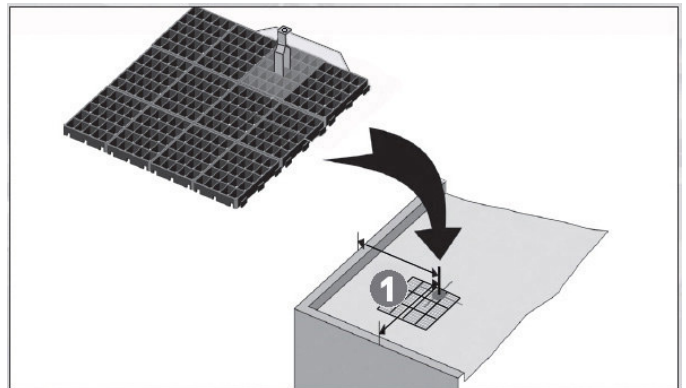

4. Positioning the first unit of grid elements and the rail support.

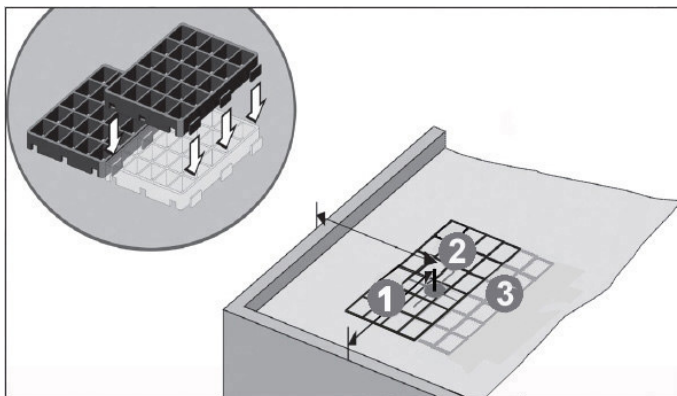

5. Connecting the second and the third unit of grid elements (third unit only with start and end grids).

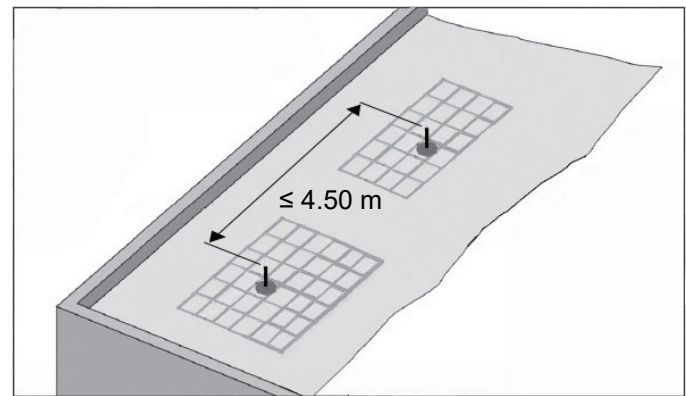

6. Do not exceed the maximum distance of 4.5 m between two rail supports!

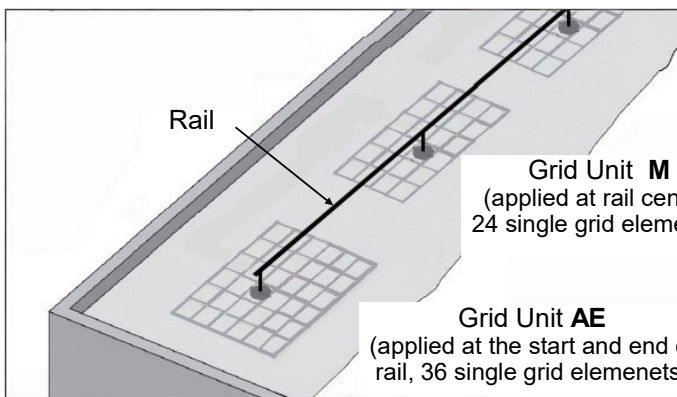

7. Assembly of the rails over the rail supports including joint connectors and end pieces as well as insertion of the gliding anchoring point (runner).

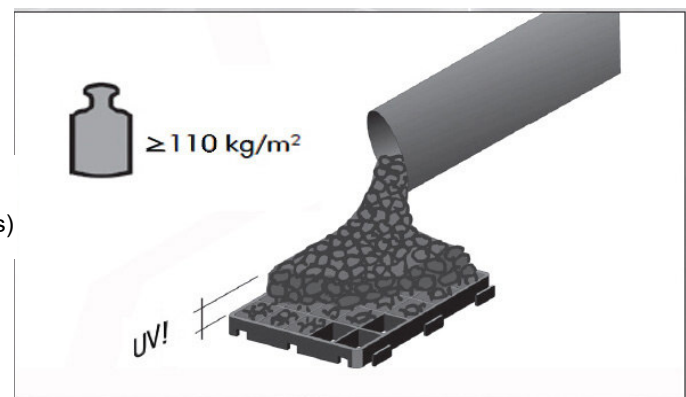

8. Applying the required load (min. 110 kg/m² dry weight)